

FWE Bubble Paper Pressing Machine User Manual

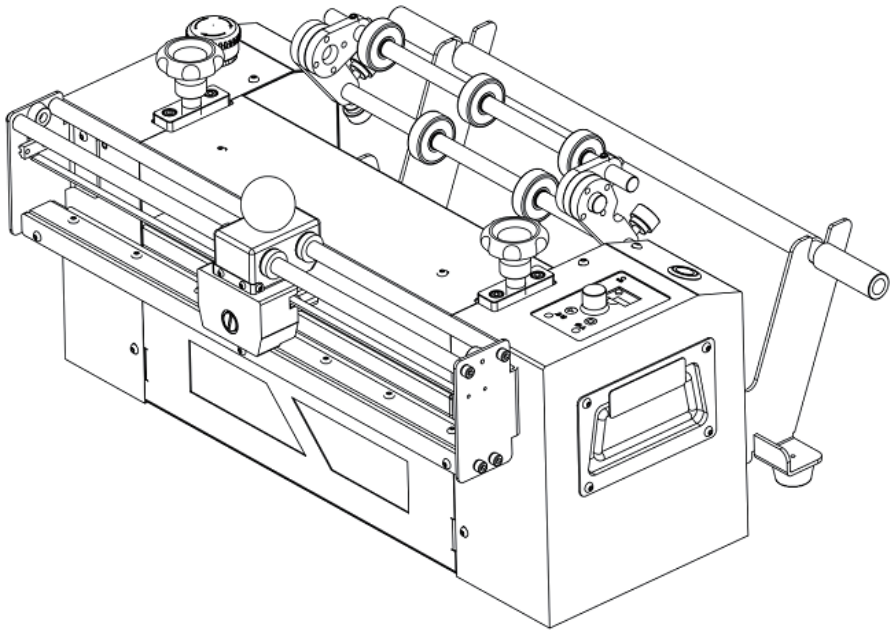

Before installing and using the product, please read the User Manual carefully and keep it properly.

Preface

- Thank you for choosing our products. We will provide you with high-quality products and reliable after-sales service.
- To ensure the personal safety of users and the integrity of the equipment, please be sure to read this Manual.

Special Notes

- This User Manual shall not be used as a basis for making any claims against our Company.
- Our Company reserves the right to interpret this User Manual.

Product Usage

FWE bubble paper pressing machine is a simple and easy-to-use machine with concise and clear operating interface and easy operation. With metal housing, the machine features more sturdy structure and compact size and exquisite appearance. With wide range of applicability, it is a cost-effective choice for small factories, warehouses and shops. Formed kraft paper is adopted to package the product or fill the inner box. It can effectively increase the speed of packaging products and reduce the labor intensity of operators.

Special Notes

- Small size, saving space;
- Simple operation, convenient and practical;
- Strong, durable, stable and shockproof;
- Good buffering performance, energy saving and eco-friendly;

Product parameters

Product name	Bubble Paper Pressing Machine
Product Model	FWE340
Supply voltage (V/Hz)	110~220V/50~60Hz
Power consumption (W)	210W
Machine weight (kg)	27.5KG (Gross weight: 29.5KG)
Dimensions LxWxH (mm)	537x194x214MM
Maximum speed (m/min)	15m/min
Environmental Conditions	Temperature: 5~40°C; Humidity: < 85%RH

Precautions

1. Do not use it in a humid environment;
2. Before operation, please note the followings:
 - If the machine is not properly grounded, it may cause electric shock.
 - Do not remove protective cover or access cover. It should be opened only by the service personnel of our company or authorized dealer.
 - Keep fingers, hair, clothing and jewelry away from the paper cutter during operation or loading of materials to avoid entanglement or cuts.
3. When stopping operation, turn the switch to the STOP position before turning off the Power Supply switch.

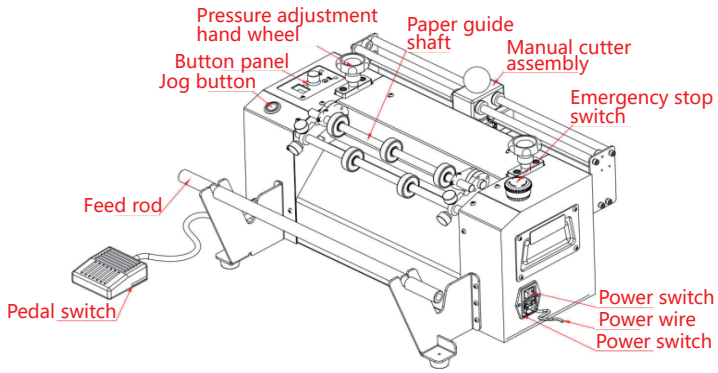

Figure 1 (Full view of the machine)

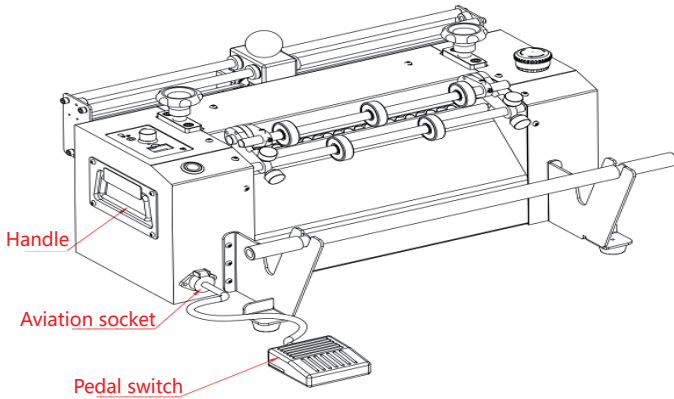
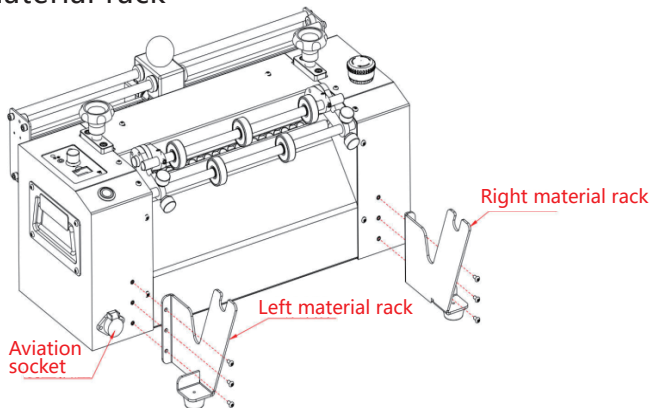

Figure 2 (Full view of the machine)

Product Installation

1. Install the material rack



2. Install the manual cutter assembly at the rear of the machine as shown in the figure

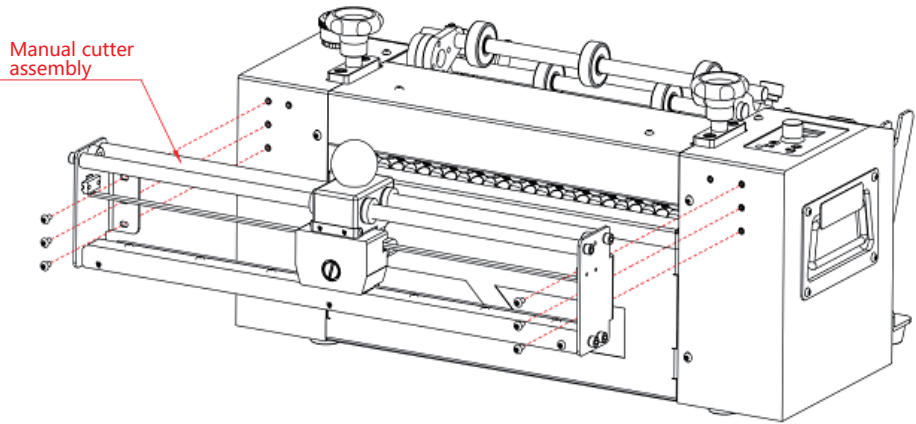

3. Put the kraft paper into the feeding rod and put it on the material rack,

4. After connecting the power supply to the power socket, turn on the POWER switch.

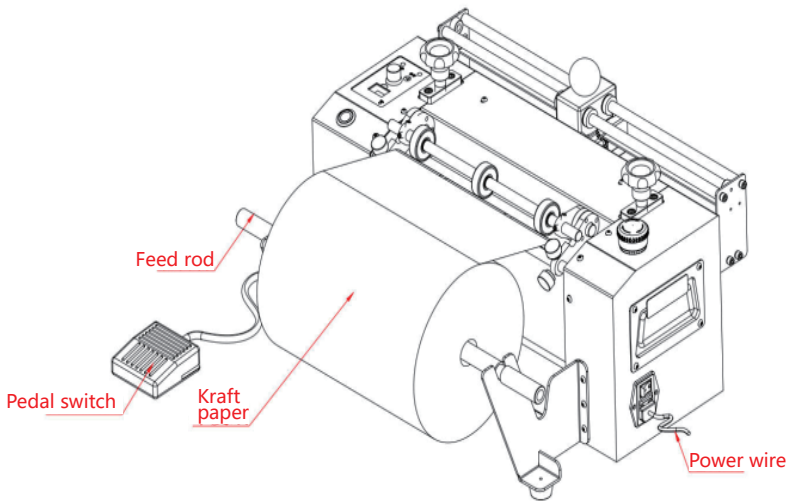

5. After the kraft paper is wound around the guide rod, pass it into the machine and pull it close to the roller

6. Press the START button and the machine starts running automatically.

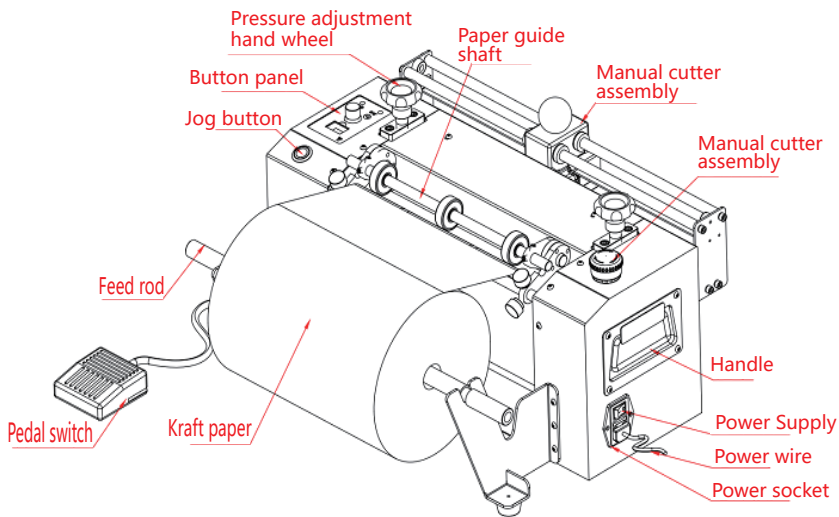

Operation Interface Description

Operation indicator

(When the machine is in the startup state, the indicator is on)

Display screen

(It is used to display the speed of output paper, the highest speed is 100, the lowest is speed 000)

Speed adjustment knob

(It is used to adjust the speed of paper output)

START button

(After pressing it, the operation indicator turns on and the machine enters the startup state)

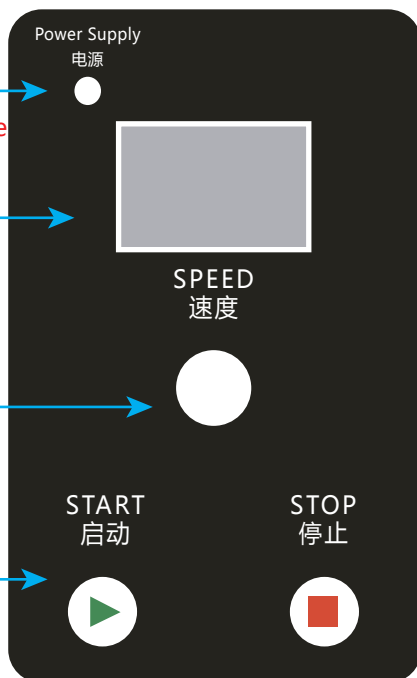

Maintenance

1. Preventive maintenance

Warning: When maintaining or repairing the machine, be sure to turn off the machine and unplug the main power wire from the socket.

Maintenance cycle	Content	Description
Once a week	Checking and cleaning	<ol style="list-style-type: none"> 1. Open the protective cover of the machine and blow away the dust and debris inside; 2. Check machine parts for abnormal wear.
Every year	Contact	<ol style="list-style-type: none"> 1. Arrange once on-site inspection; 2. Contact the authorized dealer or our technical service representative to check the equipment.

Parts List

Parts List					
Name	Unit	Quantity	Name	Unit	Quantity
2.5mm inner hexagon wrench	Each	1	User Manual	Each	1
3mm inner hexagon wrench	Each	1	Power wire	Pc	1
4mm inner hexagon wrench	Each	1	Support feet	Each	2
Pedal switch	Each	1	Manual cutter assembly	Set	2
Remarks:					

Warranty Card and Certificate of Conformity

Warranty Card		Warranty Terms
Product Model:	FWE340	<p>Dear client, Thank you for purchasing our products. In order to protect your legal rights and interests and relieve your worries, and to improve after-sales service to customers, we have specially formulated this warranty regulation. Please read it carefully and provide valuable opinions and suggestions to us.</p> <p>I. Our products enjoy a 12-month free warranty service from the date of sale. If the product warranty period exceeds 12 months from the date of sale, our Company will charge the cost of parts at its discretion depending on the product failure.</p> <p>II. Please pack the product properly when sending it for repair. Our Company will not be responsible if the product is damaged or lost during transportation.</p> <p>III. During the free warranty period, in case of the following circumstances, our Company has the right to refuse service or charge material and service fees at its discretion.</p> <p>1. Improper use by the user causes product failure or damage; 2. Accidents caused by electric shock or burning due to improper installation; 3. Damage caused by repairs by someone other than the maintenance service provider; 4. The product label is damaged;</p> <p>IV. Please read the User Manual carefully before installing and using our products.</p> <p>V. Please have the seller stamp and date the warranty card to ensure your rights.</p>
Date of Sale:		
Dealer:		
<p>*This Certificate will only be effective after being affixed with the official seal of our Company</p>		

Product Conformity Certificate

Name: Bubble paper pressing machine Inspection :  _____

Model: FWE340 Inspector:  _____

Date: _____

This product has been inspected and is allowed to leave the factory as qualified