

Honeycomb paper automatically
produces the paper machine

---FWB525M

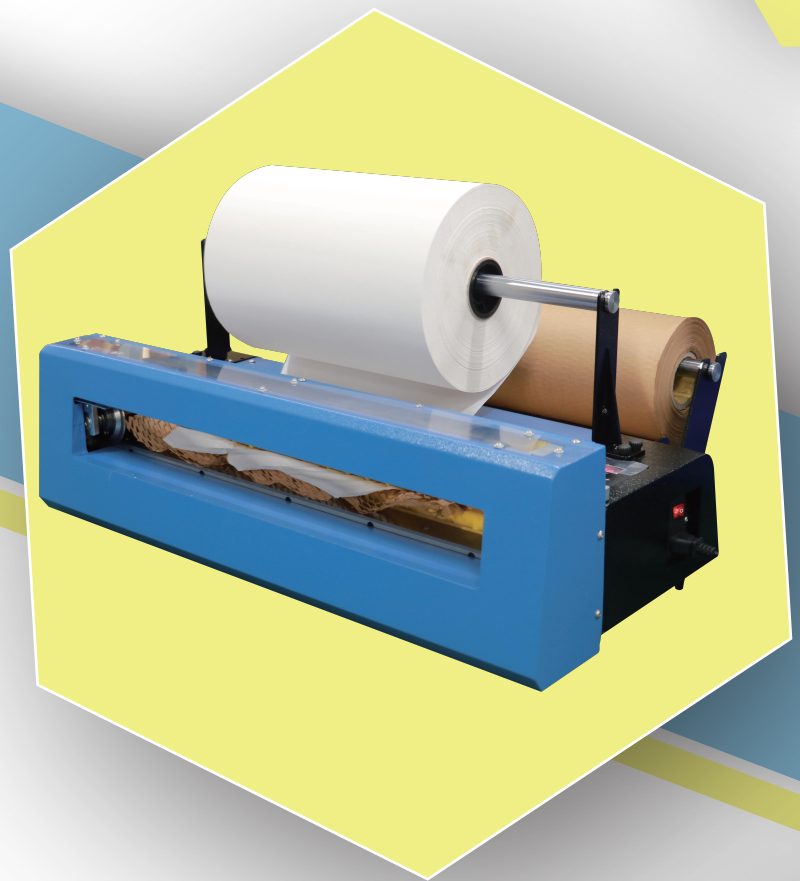

Product instructions for use

Before installing and using the product, please read the instruction manual carefully, and properly keep and spare!

www.AirPackagingMachine.com

Preface

Thank you for choosing the products of the company, the company sincerely provides our distinguished customers with excellent quality products, and will provide professional and reliable after-sales service.

To ensure the personal safety of the users and the safety and integrity of the instruments. Please use it in strict accordance with this instruction manual.

Special explanation

This instruction shall not be used as a basis for any request to the Company.

The company has the right to interpret this instruction manual.

Product use

[Honeycomb paper automatic issuing machine] It is suitable for honeycomb wrapping paper. Because the honeycomb wrapping paper has a pre-cut hole, the wrapping machine will stretch the honeycomb paper wrapping paper Three-dimensional structure, can effectively support and package items, play a good buffer role. The honeycomb paper issuing machine can also place the Sydney paper at the same time. When the machine is running, take the honeycomb paper and Sydney paper together to simplify the packaging steps and make the product packaging in one step and easy to use.

Product characteristics

- 1, Double drum differential operation, high stability
- 2, High power and high capacity motor, longer service life
- 3, Belt drive system, light noise, small vibration
- 4, High temperature resistant silica gel, corrosion resistance, nontoxic, high temperature resistance
- 5, The independent buffer spring is fixed structure, smooth and no lag
- 6, Independent research and development of control panel, simple interface, perfect function and convenient operation.
- 7, Structural design is more reasonable, small in appearance, and portable in use

Product Parameter

Maximum honeycomb paper diameter (mm)	230mm
Maximum honeycomb paper length (mm)	510mm
Power Supply Voltage (V / Hz)	110~220V/50~60Hz
Consumed power (W)	230w
Net weight (kg)	21kg
Machine gross weight (kg)	24kg
Appearance dimensions LWH (mm)	689×496×315mm
Outer box dimensions LWH (mm)	720mm*450mm*200mm
Top speed (m / min)	25m/min
Ambient condition	Temperature Temperratur5~40 ° C; 850% RH of humidity Humidity

Instructions for product installation and use

1. Install bracket

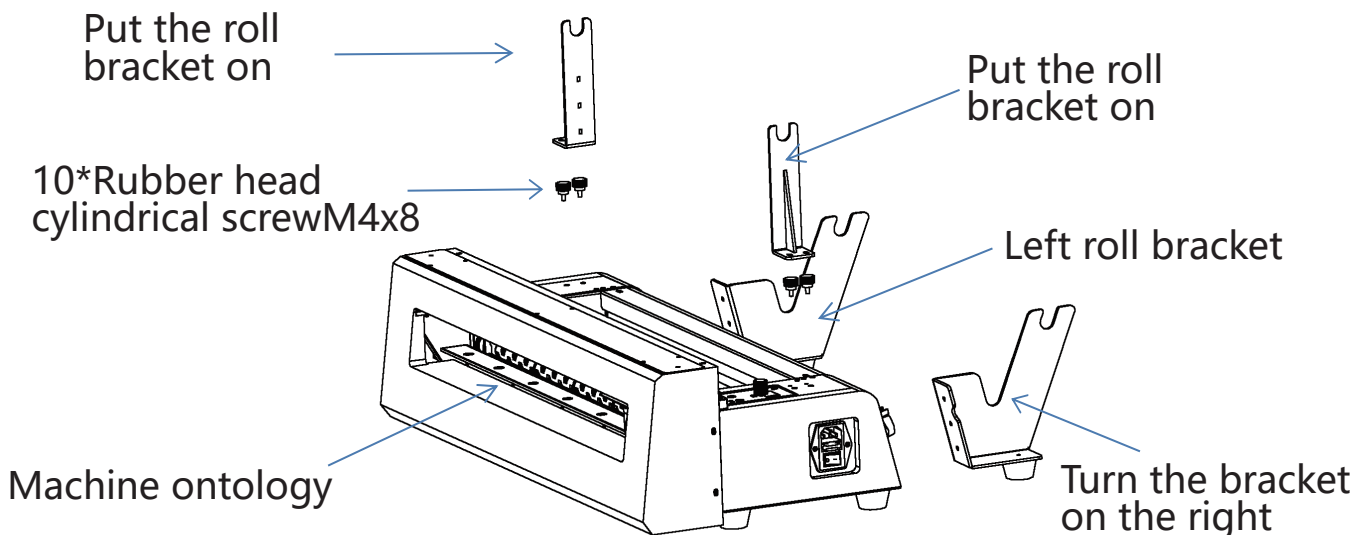

2. Put the honeycomb wrapping paper and snow pear paper into the bracket rod, and put it into the machine card slot. Then connect the power supply and the foot switch.

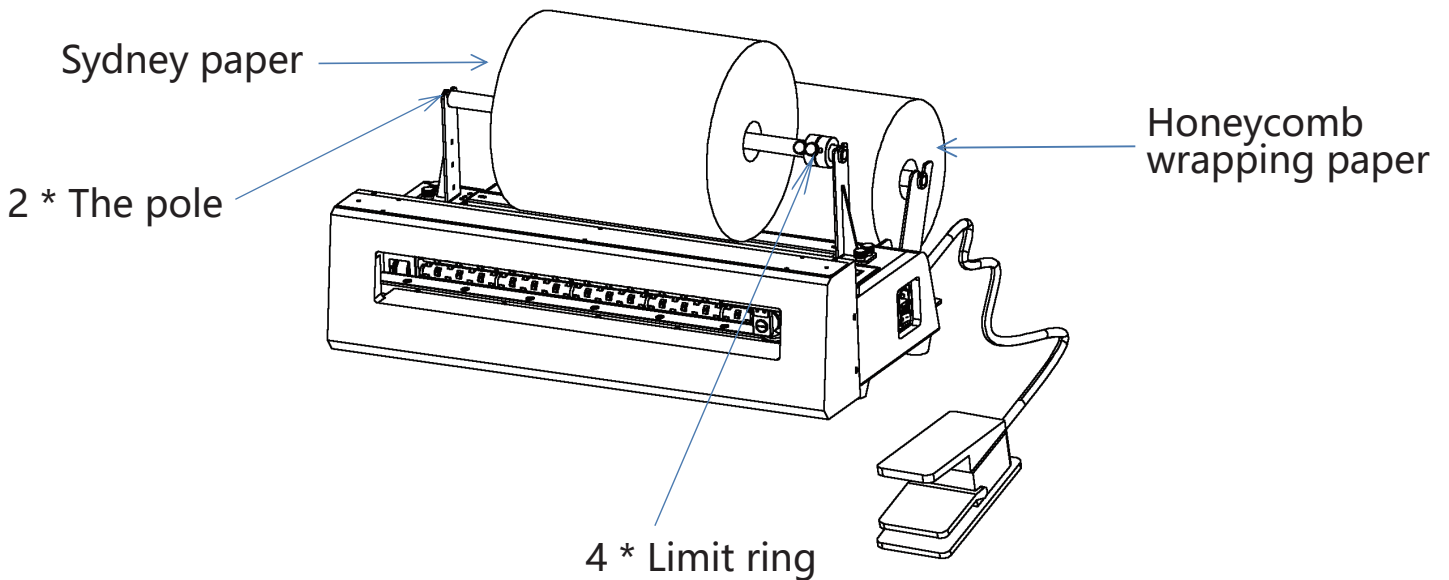

3, Start the machine to step on the foot switch once, and then put the paper close to the drum, the drum will automatically inhale the paper, and then step on the foot switch drum will stop sending paper and cut the paper once.

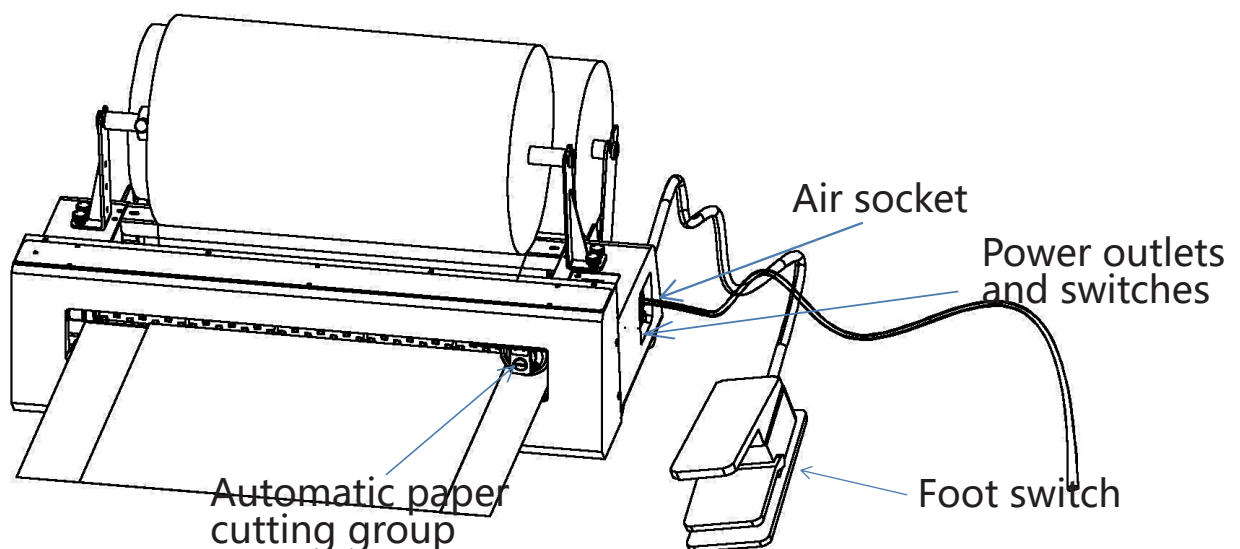

Operating interface description

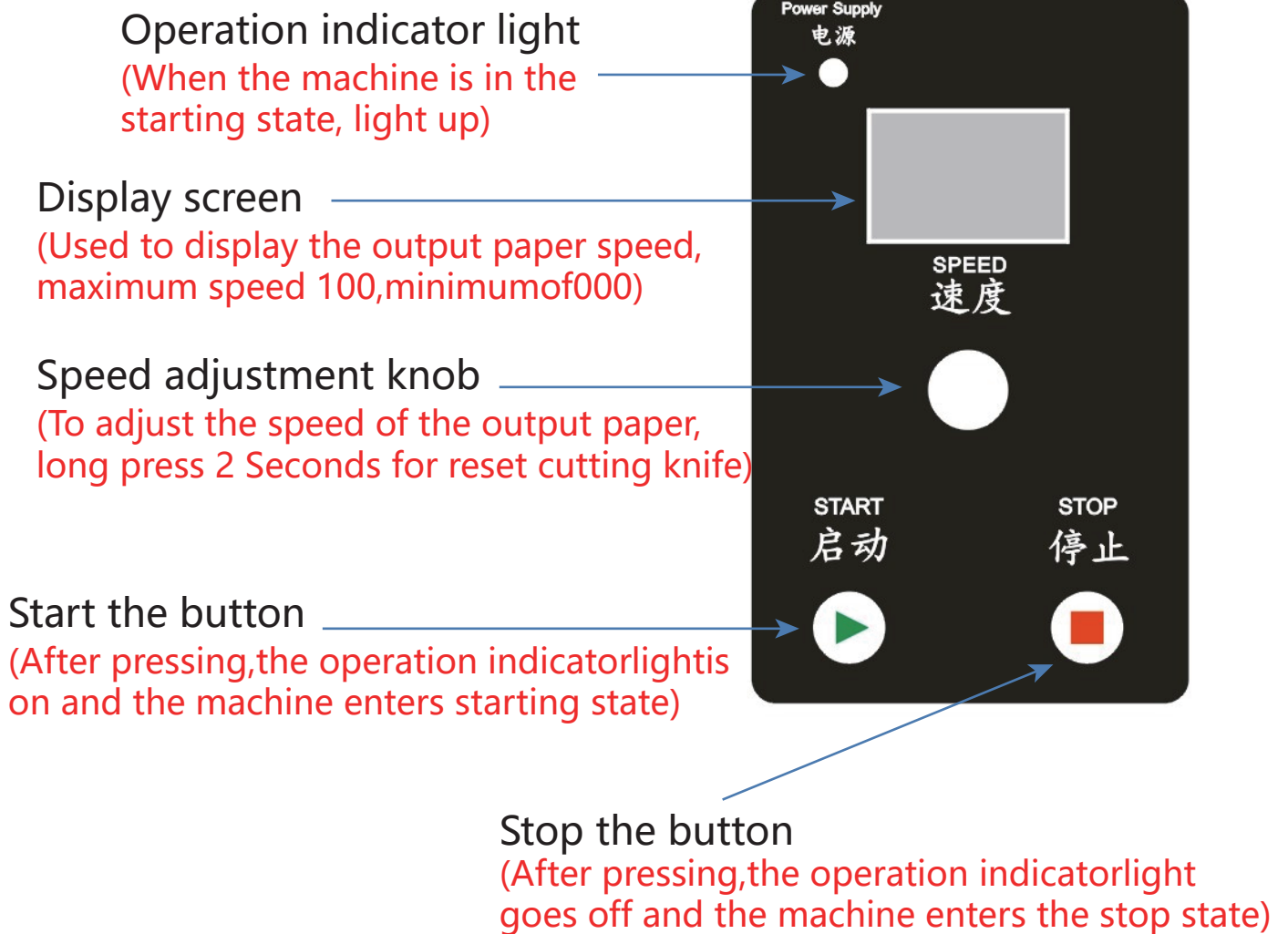

Our service purpose

Quality first

Customer orientation

Pioneering and innovating

Steady development

Abide by credit

People oriented

